

Idaho Central Vacuum AIRMASTER®

MANUFACTURED BY
MD
CENTRAL VACUUMS

SPECIFICATIONS FOR MODEL

A650t

#A1156AJ 120 VOLT

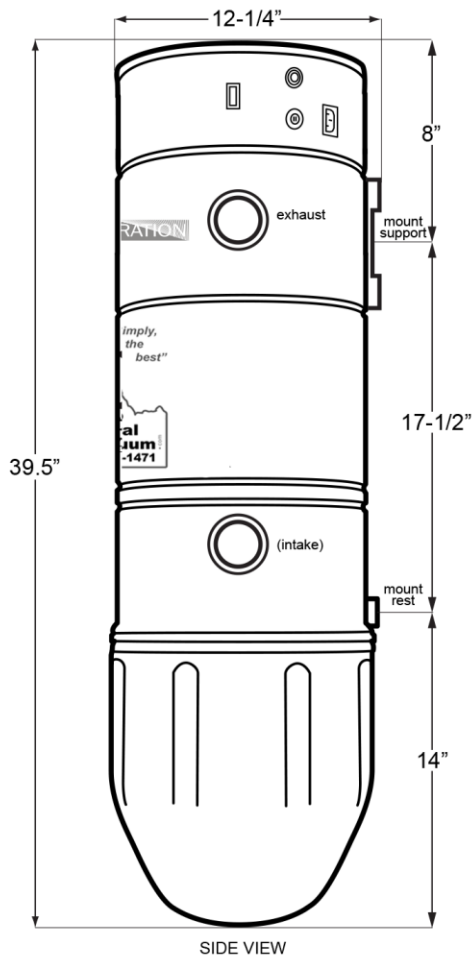

SIDE VIEW

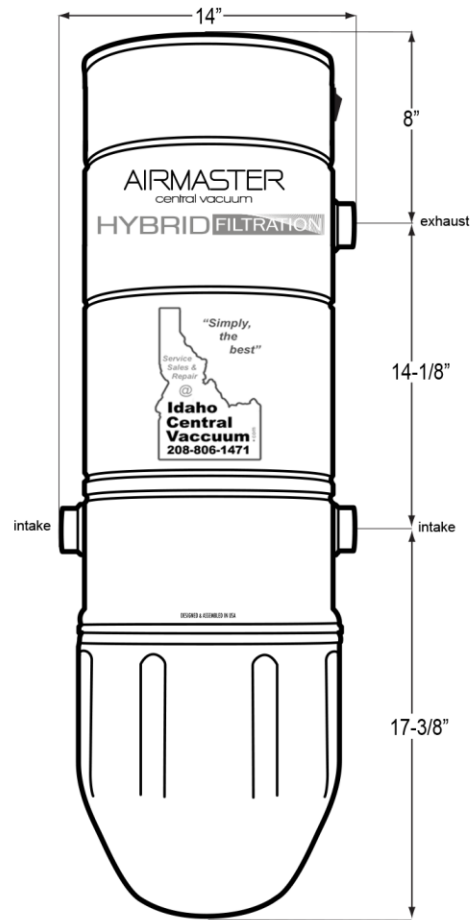

FRONT VIEW

PERFORMANCE

Sealed Vacuum 143.1"
CFM 130.2
Air Watts 650
Volts 120
Amperage 15
Quietness 60dB_A
Coverage 8,000 ft²

*Recommended home size can be higher or lower when considering these factors: altitude, hours of use, complexity of pipe installation, distance of furthest inlet, noise level, type and size of filtration, and budget.

FEATURES

Motor: Single 2-stage thru-flow motor producing high CFM & waterlift.
Filtration: Inverted MicroTex cloth filter and optional closed Microfilter disposable bag. 5-gallon capacity.
Intakes: Right & left intakes. Air relief valve.
Construction: Durable powder-coated all steel body. High Impact ABS Bucket.
Overload: Heat protection resettable minibreaker.
Warranty: 10 Years Transferable + Lifetime.
Dims/Weight: 12" Diameter, 39.5" Tall, 29 lbs.
Accessories: All MD accessories and kits are compatible and are sold separately.
Required: Air relief valve must be installed in the back side of opening.
Optional: Muffler.

INSTALLATION

Electrical:
120V 50/60HZ, 20 amp circuit.
Separate circuit recommended.
6' Cord with standard plug fits NEMA 5-20R receptacle.
Mounting:
Single stud mounting. Easy to hang and remove. Mount high or low.
Venting:
Exterior venting not necessary.
30ft maximum line if venting.

PROJECT		LOCATION	
DEALER		DATE / PRICE	



Designed & Assembled in USA

www.idahocentralvacuum.com/airmaster
sales@idahocentralvacuum.com

Idaho Central Vacuum
Meridian Idaho
208-806-1471