

Idaho Central Vacuum SILENTMASTER®

MANUFACTURED BY
MD
CENTRAL VACUUMS

SPECIFICATIONS FOR MODEL

S720r²

#S2254ND 240 VOLT

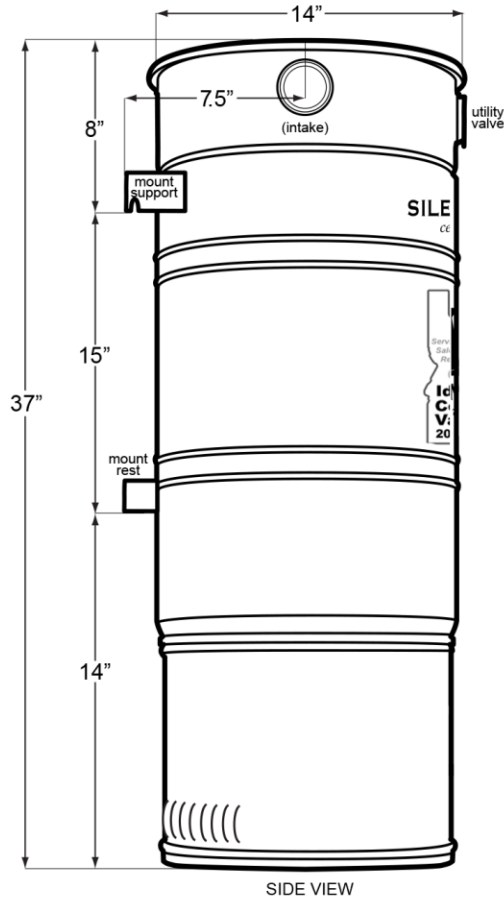

SIDE VIEW

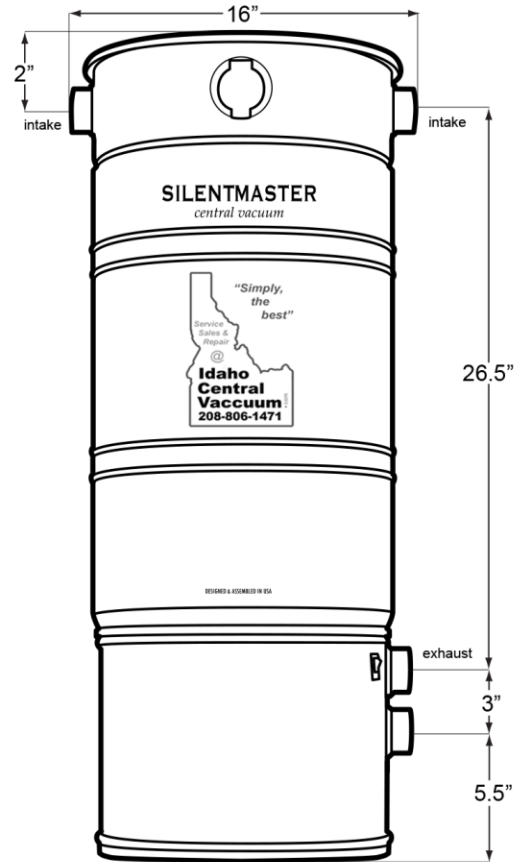

FRONT VIEW

PERFORMANCE

Sealed Vacuum	95"
CFM	208
Air Watts	722
Volts	240
Amperage	9.8
Quietness	62dB _A
Coverage	8,000 ft ²

*Recommended home size can be higher or lower when considering these factors: altitude, hours of use, complexity of pipe installation, distance of furthest inlet, noise level, type and size of filtration, and budget.

FEATURES

- Motor:** Two 2-stage radial bypass motors producing high CFM.
- Filtration:** Tru-Seal™ Microfiltration disposable 8-gallon bag, closed top.
- Intakes:** Right & left intakes. Utility valve.
- Construction:** Durable powder-coated all steel body.
- Overload:** Heat protection resettable minibreaker.
- Warranty:** 12 Year Transferable + Lifetime.
- Dims/Weight:** 14" Diameter, 37" Tall, 43 lbs.
- Accessories:** All MD accessories and kits are compatible and are sold separately.
- Optional:** Air Relief Valve, Mufflers.

INSTALLATION

- Electrical:**
 - 240V - 50/60HZ, 15 amp circuit.
 - Separate circuit recommended.
 - 6' Cord with typical 240v plug.
 - Fits NEMA 6-20R receptacle.
- Mounting:**
 - Two-stud 17" wide bracket. Easy to hang and remove. Left/right variable positioning. Mount 6" off ground. Leave 24" above unit.
- Venting:**
 - Exterior venting not necessary.
 - 30ft maximum dual line if venting.

PROJECT	LOCATION
DEALER	DATE / PRICE



Designed & Assembled in USA

www.idahocentralvacuum.com/silentmaster
sales@idahocentralvacuum.com

Idaho Central Vacuum
Meridian Idaho
208-806-1471